

**FABMOTOR**  
INDUCTION MOTOR

利林馬達

# 低壓感應電動機

AEVF/AEEF Series

ETVF/ETEF Series

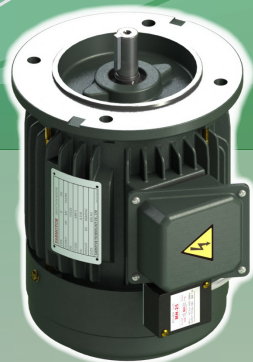
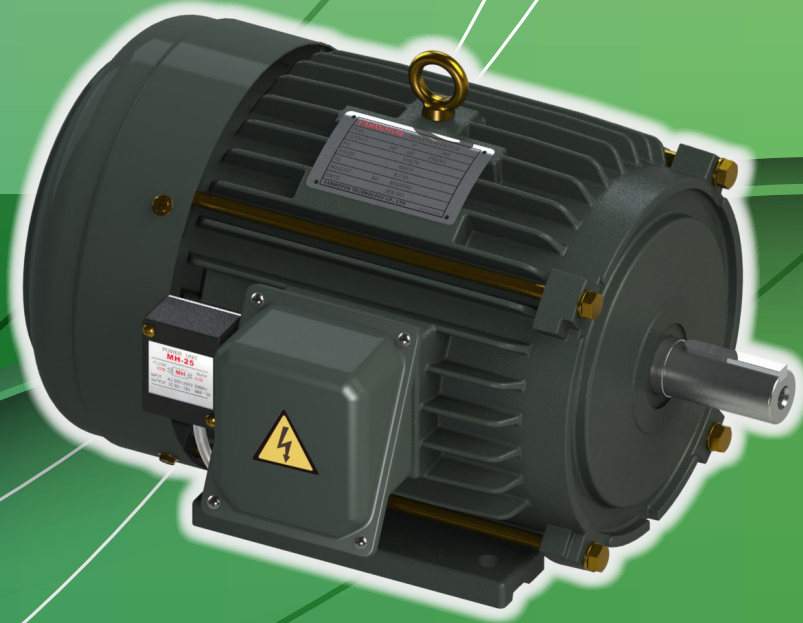

CE

[2013]

## 標準規範表

### Standard Specification Table

#### 規格 Specification

種類 Type	三相鼠籠式感應電動機 Three-Phase Squirrel Cage Induction Motor			
輸出馬力 Output Power	AEVF/AEEF	2P : 1/4HP~25HP 4P : 1/4HP~20HP 6P : 1/4HP~15HP	ETVF/ETEF	- 4P : 1/4HP~5HP 6P : 1/4HP~3HP
電壓 Voltage	額定電壓 Rated Voltage 220V、380V			
頻率 Frequency	額定頻率 Rated Frequency 50Hz、60Hz			
保護方式 Protection Type	IP54 : 全密式外扇型 Totally Enclosed Fan Type			
冷卻方式 Cooling Type	IC411 : 全密式自帶外扇冷卻 Total Enclosed Fan Cooling			
安裝方式 Mounting Type	AEVF/ETVF : 凸緣型安裝 Flange Mounted AEEF/ETEF : 水平腳座安裝 Horizontal Feet Mounted			
絕緣等級 Insulation Class	B 級 B Grade			
塗裝 Painting	防鏽處理、酚樹脂底漆、磁漆 Antirust treatment, primerpainting of phenol and surface enamel painting.			
軸承 Bearing	為預注油脂式雙遮蓋密閉式滾珠軸承 Dual cover enclosed ball bearings with grease injected beforehand.			

#### 適用 Applicable

場所 Location	屋內，需裝置於平坦及堅固的底部 Indoor; the product should be installed on flat and solid foundation.
標高 Altitude	海拔 1000 公尺以下 Under 1000m height above sea level.
濕度 Humidity	相對溼度 80% 以下 Relative Humidity Max 80%
周溫 Ambient Temperature	-15°C ~40°C
電源 Power Source	電壓變動率：±10% 以內 Voltage Deviation : Max±10% 頻率變動率：±5% 以內 Frequency Deviation : Max±5%
轉向 Rotation Wise	雙轉向 Dual Rotation Wise
啟動方式 Start Form	全壓直接啟動或 Y - Δ 啟動 Full voltage direct start or Y - Δ start.

特性表 Character List :

(220V, 3 φ 60Hz)

輸出 Output				框號 Frame No.	滿載特性 Full Load Character				起動特性 Starting Character		最大轉矩 (%) Max. Torque	轉子慣量 (kg·m <sup>2</sup> ) Inertia
HP	KW	Pole	RPM		轉矩 (kg-m) Torque	效率 (%) Efficiency	功率因素 (%) Power Factor	電流 (Amp.) Current	轉矩 (%) Torque	電流 (Amp.) Current		
0.25	0.18	2	3260	63	0.054	61	77	0.82	400	6	370	0.002
		4	1610	63	0.11	65	76	0.95	250	6	240	0.002
		6	1110	71	0.162	64	60	1.3	260	6	290	0.007
0.5	0.37	2	3335	71	0.105	75	86	1.5	340	12	310	0.002
		4	1645	71	0.213	73	74	2	200	12	250	0.005
		6	1115	80	0.32	68	67	2.2	200	12	240	0.009
1	0.75	2	3330	80	0.213	77	87	2.9	220	19	280	0.005
		4	1675	80	0.284	75	74	3.4	250	19	280	0.009
		6	1120	90L	0.635	76	71	3.6	200	19	240	0.017
2	1.5	2	3355	90L	0.422	80	89	5.5	250	40	280	0.01
		4	1685	90L	0.845	79	81	6.1	220	40	280	0.017
		6	1120	100L	1.273	78	74	6.8	180	40	220	0.033
3	2.2	2	3385	90L	0.63	82	89	8.1	230	68	280	0.015
		4	1700	100L	1.235	81	81	8.5	210	68	260	0.033
		6	1135	112M	1.877	82	77	11.8	180	68	270	0.059
5	3.7	2	3415	112M	1.041	84.5	90	12.9	240	110	340	0.038
		4	1750	112M	2.05	85	75	15	220	110	300	0.059
		6	1135	132S	3.128	84	77	17	180	110	230	0.151
7.5	5.5	2	3435	132S	1.55	90	90	19.2	220	160	260	0.063
		4	1715	132S	3.111	83	84	20.1	230	160	280	0.104
		6	1135	132M	4.689	76	77.5	22.3	200	160	230	0.217
10	7.5	2	3440	132S	2.068	90	90	25.1	200	200	270	0.076
		4	1715	132M	4.145	88	88	25.1	220	200	250	0.143
		6	1150	160M	6.178	79	80	28.1	280	200	300	0.4
15	11	2	3470	160M	3.076	90	90	37.1	220	290	300	0.147
		4	1725	160M	6.183	88	89	36.7	220	290	250	0.297
		6	1145	160L	9.306	84	84	39.1	240	290	260	0.588
20	15	2	3450	160M	4.12	90	91	48.1	210	360	260	0.183
		4	1725	160L	8.248	86	86	50.3	230	360	260	0.381
25	18.5	2	3520	160L	5.12	89	87	62	230	480	250	0.225

特性表 Character List :

(380V, 3 φ 50Hz)

輸出 Output				框號 Frame No.	滿載特性 Full Load Character				起動特性 Starting Character		最大轉矩 (%) Max. Torque	轉子慣量 (kg·m <sup>2</sup> ) Inertia
HP	KW	Pole	RPM		轉矩 (kg-m) Torque	效率 (%) Efficiency	功率因素 (%) Power Factor	電流 (Amp.) Current	轉矩 (%) Torque	電流 (Amp.) Current		
0.25	0.18	2	2670	63	0.062	71	76.5	0.53	400	3.5	330	0.002
		4	1320	63	0.125	62	68.5	0.65	220	3.5	240	0.002
		6	900	71	0.198	52	60	0.79	260	3.5	270	0.007
0.5	0.37	2	2760	71	0.127	78	85	0.89	320	6	280	0.002
		4	1345	71	0.245	72	73	1.24	200	6	230	0.005
		6	910	80	0.389	57	67	1.34	200	6	230	0.009
1	0.75	2	2745	80	0.259	77.5	78	1.9	220	11	280	0.005
		4	1370	80	0.518	75	73	2.13	250	11	280	0.009
		6	930	90L	0.764	61	70	2.28	190	11	230	0.017
2	1.5	2	2785	90L	0.511	82	82	3.4	250	23	280	0.01
		4	1375	90L	1.036	85	66	4	220	23	280	0.017
		6	910	100L	1.561	74	45	6.7	180	23	220	0.033
3	2.2	2	2790	90L	0.765	83	85	4.6	250	38	280	0.015
		4	1405	100L	1.515	81	73	5.6	210	38	260	0.033
		6	935	112M	2.28	84	50	7.8	180	38	230	0.059
5	3.7	2	2820	112M	1.258	84	83	7.7	240	63	320	0.038
		4	1415	112M	2.512	80	64	11	220	63	290	0.059
		6	940	132S	3.78	65.5	75.5	9.15	180	63	230	0.151
7.5	5.5	2	2845	132S	1.872	86.5	88.5	11.1	210	92	260	0.062
		4	1415	132S	3.765	86	82.5	12	220	92	280	0.104
		6	940	132M	5.671	84.5	77.5	13	200	92	230	0.216
10	7.5	2	2850	132S	2.494	88.5	88.5	14.5	200	115	250	0.076
		4	1420	132M	5.006	87.5	85.5	15.2	220	115	250	0.142
		6	955	160M	7.445	86	80	16.5	270	115	300	0.4
15	11	2	2880	160M	3.701	88.5	90	21.3	210	168	290	0.146
		4	1430	160M	7.455	89.5	88	21.6	220	168	250	0.297
		6	950	160L	11.225	88.5	84	22.9	220	168	260	0.588
20	15	2	2860	160M	4.97	90	91	27.7	210	207	260	0.183
		4	1435	160L	9.907	90.5	88.5	28.3	230	207	260	0.38
25	18.5	2	2920	160L	6.12	89	87	34.2	230	268	250	0.225

註：1. 上列標稱代表值為實測值 2. 以上數值若有變更，恕不另行通知

Remark : 1.The above the nominal representative value of the measured value 2.The above mentioned value subject to change without notice

# 立式標準馬達 / A E V F 系列

# Vertical Motor / AEVF Series

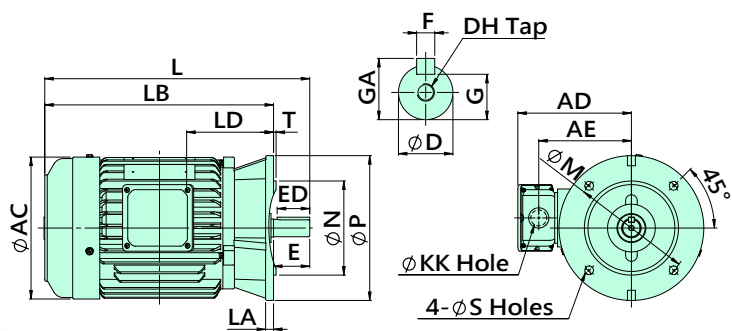

Fig.1

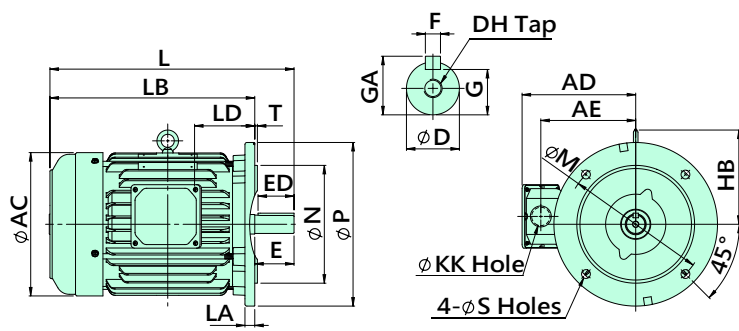

Fig.2

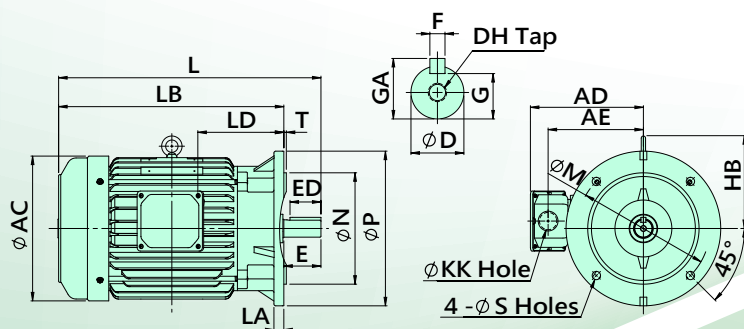

Fig.3

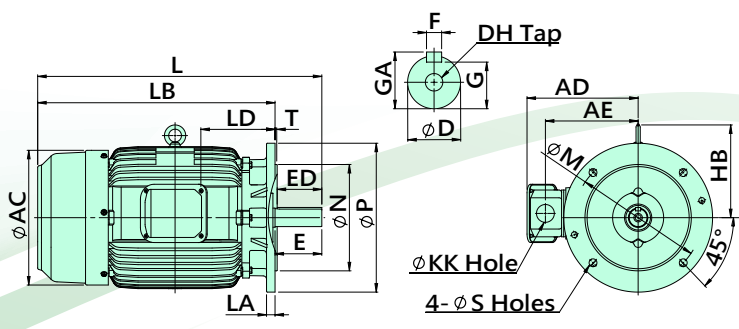

Fig.4

(mm)

## 尺寸表 Dimension

輸出 Output (HP)			框號 FRAME NO.	圖號 FIGURE NO.	AC	AD	AE	HB	KK	L	LA	LB	LD	安裝尺寸 Mounted Size				
2P	4P	6P												M	N	P	S	T
1/4	1/4	-	63	1	142	131.5	103	-	22	245.5	11	222.5	78	130	110	160	10	3.5
1/2	1/2	1/4	71	1	156	131.5	105	-	22	271	10	241.5	85	130	110	160	10	3.5
1	1	1/2	80	2	175	146.5	118	-	22	274	12	234	64	165	130	200	12	3.5
2	3	2	90L	3	196	156.5	128	-	22	367	11	317	120	165	130	200	12	3.5
-	3	2	100L	2	219	173	145	144	28	373	15	313	92	215	180	250	13.5	4
5	5	3	112M	3	234	182	154	150	28	425	16	365	154	215	180	250	13.5	4
7.5	10	7.5	132S	2	274	226	180	169	35	450	20	372	102	265	230	300	14.5	4
-	10	7.5	132M	2	274	226	180	169	35	489	20	408	118	265	230	300	14.5	4
15	20	15	160M	4	334	262	218	216	35	602	20	496	153	300	250	350	14.5	5
25	20	15	160L	4	334	262	218	216	35	648	20	541	175	300	250	350	14.5	5

輸出 Output (HP)			框號 FRAME NO.	圖號 FIGURE NO.	軸 端 End Of Shaft							軸 承 Bearings		重量 Weight (KGS)
2P	4P	6P			D	E	ED	F	G	GA	DH	負載端 L. S.	反負載端 O. S.	
1/4	1/4	-	63	1	11	23	20	4	8.5	12.5	M4x8	6201ZZ	6201ZZ	10
1/2	1/2	1/4	71	1	14	30	25	5	11	16	M5x10	6203ZZ	6202ZZ	12
1	1	1/2	80	2	19	40	35	6	15.5	21.5	M6x12	6204ZZ	6203ZZ	15
2	3	2	90L	3	24	50	45	8	20	27	M8x16	6205ZZ	6204ZZ	24
-	3	2	100L	2	28	60	55	8	24	31	M10x20	6206ZZ	6205ZZ	31
5	5	3	112M	3	28	60	55	8	24	31	M10x20	6306ZZ	6305ZZ	41
7.5	10	7.5	132S	2	38	80	75	10	33	41	M12x24	6308ZZ	6306ZZ	64
-	10	7.5	132M	2	38	80	75	10	33	41	M12x24	6308ZZ	6306ZZ	76
15	20	15	160M	4	42	110	105	12	37	45	M16x32	6309ZZ	6307ZZ	118
25	20	15	160L	4	42	110	105	12	37	45	M16x32	6309ZZ	6307ZZ	136

註：1. 心軸直徑 "D" 公差：φ11~φ28 : j6 · φ38~φ48 : k6。 2. 引導直徑 "N" 公差：h7。 3. 重量誤差 3%。 4. 以上數值如有變更，恕不另行通知。

Remark : 1. Shaft dia "D" clearance : φ11~φ28 : j6 · φ38~φ48 : k6 2. Guidance dia "N" clearance : h7 3. Weight error of 3 % 4. The above mentioned value subject to change without notice

# 臥式標準馬達 / A E E F 系列

# Horizontal Motor / AEEF Series

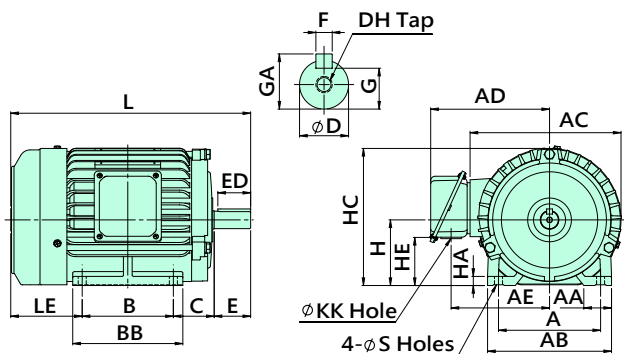

Fig.1

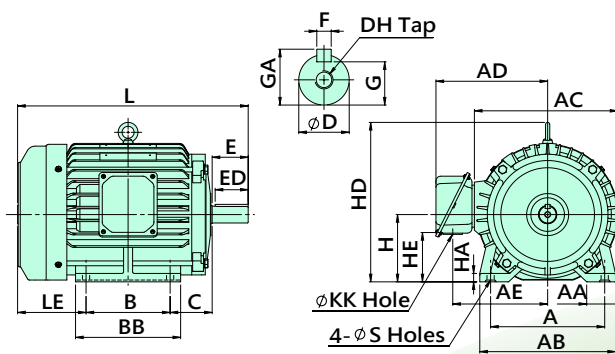

Fig.2

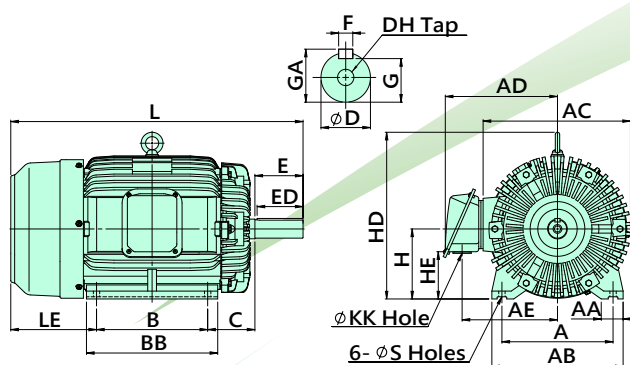

Fig.3

(mm)

## 尺寸表 Dimension

輸出 Output (HP)			框號 FRAME NO.	圖號 FIGURE NO.	AA	AB	AC	AD	AE	BB	HA	HC	HD	HE	KK	安裝尺寸 MOUNTED SIZE				
2P	4P	6P														A	B	C	H	S
1/4	1/4	-	63	1	30	120	145	123	98	101	8.5	136	-	28	22	100	80	40	63	7
1/2	1/2	1/4	71	1	38	140	156	130	105	115	10	148	-	63	22	112	90	45	71	7
1	1	1/2	80	1	43.5	155	176.5	143	115	130	10	167.5	-	57	22	125	100	50	80	10
2 3	2	1	90L	1	35	170	207	163	135	150	12.5	188	-	66	22	140	125	56	90	10
-	3	2	100L	2	46	195	221.5	176	148	175	14	-	244	68	28	160	140	63	100	12
5	5	3	112M	2	48	226	239	186	158	175	14	-	266	82	28	190	140	70	112	12
7.5 10	7.5	5	132S	2	48	250	272	224	182	175	16	-	312	82	35	216	140	89	132	12
-	10	7.5	132M	2	48	250	272	224	182	212	16	-	312	82	35	216	178	89	132	12
15 20	15	10	160M	3	52	300	334	262	220	250	18	-	378	106	35	254	210	108	160	14.5
25	20	15	160L	3	52	300	334	262	220	300	18	-	378	106	34	254	254	108	160	14.5

輸出 Output (HP)			框號 FRAME NO.	圖號 FIGURE NO.	L	LE	軸端 End Of Shaft							軸承 Bearings		重量 Weight (KGS)
2P	4P	6P					D	E	ED	F	G	GA	DH	負載端 L. S.	反負載端 O. S.	
1/4	1/4	-	63	1	206	63	11	23	18	4	8.5	12.5	M4x8	6201ZZ	6201ZZ	9
1/2	1/2	1/4	71	1	242.5	77.5	14	30	24	5	11	16	M5x10	6203ZZ	6202ZZ	11
1	1	1/2	80	1	271.5	81	19	40	25	6	15.5	21.5	M6x12	6204ZZ	6203ZZ	15
2 3	2	1	90L	1	329	98	24	50	45	8	20	27	M8x16	6205ZZ	6204ZZ	23
-	3	2	100L	2	373.5	110.5	28	60	55	8	24	31	M10x20	6206ZZ	6205ZZ	30
5	5	3	112M	2	384	114	28	60	55	8	24	31	M10x20	6306ZZ	6305ZZ	33
7.5 10	7.5	5	132S	2	448	145	38	80	75	10	33	41	M12x24	6308ZZ	6306ZZ	62
-	10	7.5	132M	2	486	145	38	80	75	10	33	41	M12x24	6308ZZ	6306ZZ	74
15 20	15	10	160M	3	598	180	42	110	105	12	37	45	M16x32	6309ZZ	6307ZZ	118
25	20	15	160L	3	646	180	42	110	105	12	37	45	M16x32	6309ZZ	6307ZZ	140

註：1. 心軸直徑 "D" 公差： $\phi 11 \sim \phi 28 : j6$ 、 $\phi 38 \sim \phi 48 : k6$ 。 2. 心軸高度 "H" 公差： $H_{-0.5}^{+0}$ 。 3. 重量誤差 3%。 4. 以上數值如有變更，恕不另行通知。

Remark : 1. Shaft dia "D" clearance :  $\phi 11 \sim \phi 28 : j6$ 、 $\phi 38 \sim \phi 48 : k6$  2. Shaft height "H" clearance :  $H_{-0.5}^{+0}$  3. Weight error of 3%  
4. The above mentioned value subject to change without notice

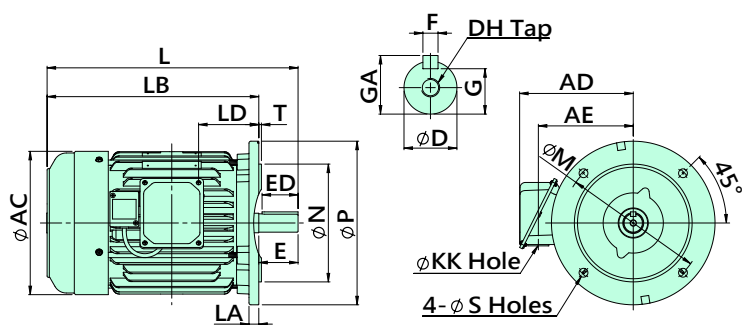

Fig.1

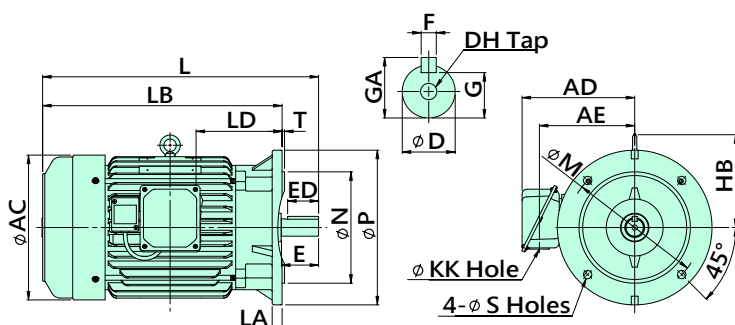

Fig.2

(mm)

尺寸表 Dimension

輸出 Output (HP)		框號 FRAME NO.	圖號 FIGURE NO.	AC	AD	AE	HB	KK	L	LA	LB	LD	安裝尺寸 Mounted Size				
4P	6P												M	N	P	S	T
1/4	-	63	1	142	131.5	103	-	22	257.5	11	234.5	78	130	110	160	10	3.5
1/2	1/4	71	1	156	131.5	105	-	22	277	10	247.5	85	130	110	160	10	3.5
1	1/2	80	2	175	146.5	118	-	22	274	12	252	64	165	130	200	12	3.5
2	1	90L	2	196	156.5	128	-	22	401	11	333	120	165	130	200	12	3.5
3	2	100L	2	219	173	145	144	28	386.5	15	326.5	92	215	180	250	13.5	4
5	3	112M	2	234	182	154	150	28	446	16	386	154	215	180	250	13.5	4

輸出 Output (HP)		框號 FRAME NO.	圖號 FIGURE NO.	軸 端 End Of Shaft							軸 承 Bearings		重量 WEIGHT (KGS)
4P	6P			D	E	ED	F	G	GA	DH	負載端 L.S.	反負載端 O.S.	
1/4	-	63	1	11	23	20	4	8.5	12.5	M4x8	6201ZZ	6201ZZ	12
1/2	1/4	71	1	14	30	25	5	11	16	M5x10	6203ZZ	6202ZZ	14
1	1/2	80	2	19	40	35	6	15.5	21.5	M6x12	6204ZZ	6204ZZ	19
2	1	90L	2	24	50	45	8	20	27	M8x16	6205ZZ	6205ZZ	29
3	2	100L	2	28	60	55	8	24	31	M10x20	6206ZZ	6305ZZ	36.5
5	3	112M	2	28	60	55	8	24	31	M10x20	6306ZZ	6306ZZ	52

註：1. 心軸直徑 "D" 公差： $\phi 11 \sim \phi 28 : j6 \cdot \phi 38 \sim \phi 48 : k6$ 。 2. 引導直徑 "N" 公差： $h7$ 。 3. 重量誤差 3%。 4. 以上數值如有變更，恕不另行通知。

Remark : 1. Shaft dia "D" clearance :  $\phi 11 \sim \phi 28 : j6 \cdot \phi 38 \sim \phi 48 : k6$  2. Guidance dia "N" clearance :  $h7$  3. Weight error of 3% 4. The above mentioned value subject to change without notice

剎車特性表 Brake Character List :

輸出 Output (HP)	Output (HP)	4 極 4-Pole	1/4	1/2	1	2	3	5
		6 極 6-Pole	-	1/4	1/2	1	2	3
框號 Frame No.			63	71	80	90L	100L	112M
額定轉矩 Rated torque (Nm)			2	4	8	15	30	40
吸引時間 Suction time (ms)			30	30	60	90	90	80
釋放時間 Release time (ms)			80	100	120	140	150	100
氣隙 Air Gap (mm)		規定值 Specified value	0.3	0.3	0.3	0.4	0.4	0.5
		限定值 Limited value	0.7	0.7	1.0	1.0	1.0	1.2

特點 Features :

1. 結構精巧：剎車構造一體化的設計，適用於空間受限場所。
2. 高頻度、壽命長：制動板與散熱風扇一體化的設計，散熱效率高，在高頻度的制動工作量下，可保持長壽命，省去保養維護的麻煩。
3. 先進的規格：採用日本進口高效非石棉材質，可耐較高頻度使用，磨耗率低且無公害。

1. Compact structure: integrated brake structure is applied to restricted space.
2. High frequency, long service life: integrated design of braking plate and cooling fan can get advantages of long service life and maintenance-free during high frequency brake operation.
3. Advanced specification: high efficient non-asbestos materials imported for Japan is durable to high frequency operation, low wearing rate and pollution-free.

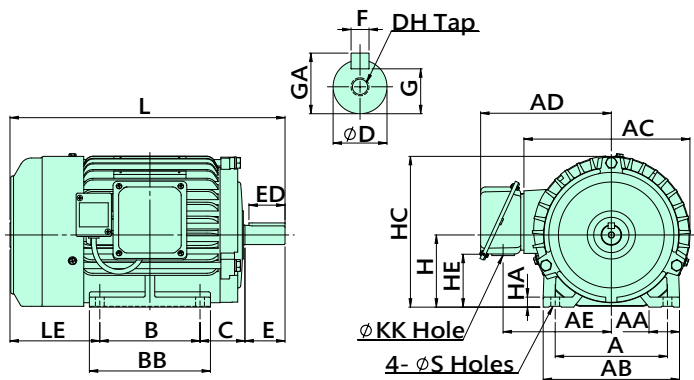

Fig.1

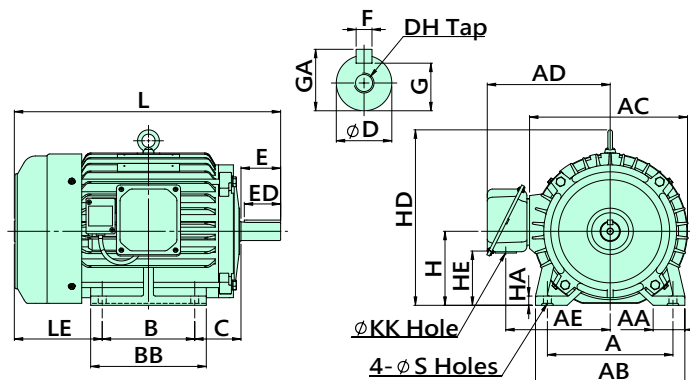

Fig.2

(mm)

尺寸表 Dimension

輸出 Output (HP)		框號 FRAME NO.	圖號 FIGURE NO.	AA	AB	AC	AD	AE	BB	HA	HC	HD	HE	KK	安裝尺寸 Mounted Size				
4P	6P														A	B	C	H	S
1/4	-	63	1	30	120	145	123	98	101	8.5	136	-	28	22	100	80	40	63	7
1/2	1/4	71	1	38	140	156	130	105	115	10	148	-	63	22	112	90	45	71	7
1	1/2	80	1	43.5	155	176.5	143	115	130	10	167.5	-	57	22	125	100	50	80	10
2	1	90L	1	35	170	207	163	135	150	12.5	188	-	66	22	140	125	56	90	10
3	2	100L	2	46	195	221.5	176	148	175	14	-	244	68	28	160	140	63	100	12
5	3	112M	2	48	226	239	186	158	175	14	-	266	82	28	190	140	70	112	12

輸出 Output (HP)		框號 FRAME NO.	圖號 FIGURE NO.	L	LE	軸 端 End Of Shaft							軸 承 Bearings		重量 WEIGHT (KGS)
4P	6P					D	E	ED	F	G	GA	DH	負載端 L.S.	反負載端 O.S.	
1/4	-	63	1	218	75	11	23	18	4	8.5	12.5	M4x8	6201ZZ	6201ZZ	11
1/2	1/4	71	1	248.5	83.5	14	30	24	5	11	16	M5x10	6203ZZ	6202ZZ	13
1	1/2	80	1	289.5	100	19	40	25	6	15.5	21.5	M6x12	6204ZZ	6204ZZ	19
2	1	90L	1	345	114	24	50	45	8	20	27	M8x16	6205ZZ	6205ZZ	27
3	2	100L	2	3387	124	28	60	55	8	24	31	M10x20	6206ZZ	6305ZZ	35.5
5	3	112M	2	405	135	28	60	55	8	24	31	M10x20	6306ZZ	6306ZZ	44

註：1. 心軸直徑 "D" 公差： $\phi 11 \sim \phi 28 : j6$ 、 $\phi 38 \sim \phi 48 : k6$ 。 2. 心軸高度 "H" 公差： $H_{-0.5}^{+0}$ 。 3. 重量誤差 3%。 4. 以上數值如有變更，恕不另行通知。

Remark : 1. Shaft dia "D" clearance :  $\phi 11 \sim \phi 28 : j6$ 、 $\phi 38 \sim \phi 48 : k6$  2. Shaft height "H" clearance :  $H_{-0.5}^{+0}$  3. Weight error of 3% 4. The above mentioned value subject to change without notice

剎車構造剖面圖 Cross Section Of Magnetic Brake System :

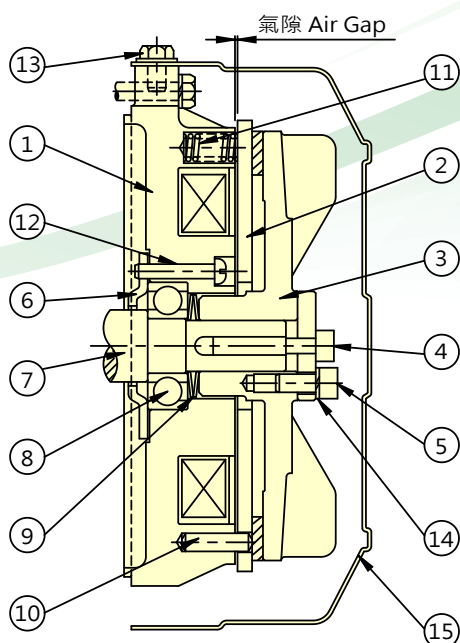

編號 NO.	零件名稱 Parts Name
1	托架 ( 附煞車線圈 ) Bracket ( Brake coil included )
2	剎車來令片 Brake Lining
3	外扇 Fan
4	調整螺絲 Adjusting Screw
5	內六角螺絲 Hex Socket Cap Screws
6	軸承壓蓋 Bearing Cover
7	軸心 Shaft
8	軸承 Bearing
9	皿形彈簧 Tray-Type Spring
10	彈簧梢 Spring Pin
11	壓縮彈簧 Compression Spring
12	圓頭十字螺絲 Philips Pan Head Screw
13	外六角螺絲 Hexagon Screw
14	彈簧華司 Spring Washer
15	風罩 Fan Guard

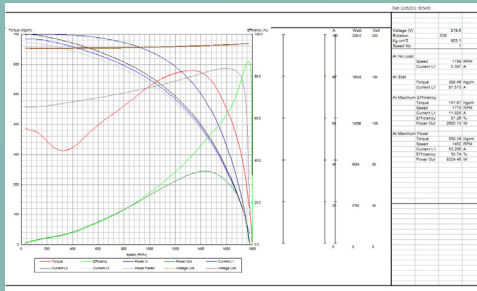

Acceleration (m/s²)	Current (A)	Power (W)	Power Factor	Efficiency (%)	Current L3 (%)	Current L2 (%)
34.24	307.1	21972	110.2	0.828	87.53	88.27
36.25	306.5	21972	110.2	0.828	87.53	88.27
41.63	305.1	21972	110.5	0.826	87.53	88.27
45.57	304.6	21972	110.2	0.825	87.53	88.27
52.45	303.4	21972	109.8	0.823	87.53	88.27
60.54	302.2	21972	109.5	0.821	87.53	88.27
69.94	301.0	21972	109.2	0.819	87.53	88.27
80.74	300.0	21972	108.8	0.817	87.53	88.27
92.94	299.0	21972	108.5	0.815	87.53	88.27
106.54	298.0	21972	108.2	0.813	87.53	88.27
121.54	297.0	21972	107.9	0.811	87.53	88.27
137.94	296.0	21972	107.6	0.809	87.53	88.27
155.74	295.0	21972	107.3	0.807	87.53	88.27
174.94	294.0	21972	107.0	0.805	87.53	88.27
195.54	293.0	21972	106.7	0.803	87.53	88.27
218.54	292.0	21972	106.4	0.801	87.53	88.27
243.94	291.0	21972	106.1	0.799	87.53	88.27
271.74	290.0	21972	105.8	0.797	87.53	88.27
302.94	289.0	21972	105.5	0.795	87.53	88.27
337.54	288.0	21972	105.2	0.793	87.53	88.27
375.54	287.0	21972	104.9	0.791	87.53	88.27
416.94	286.0	21972	104.6	0.789	87.53	88.27
461.74	285.0	21972	104.3	0.787	87.53	88.27
509.94	284.0	21972	104.0	0.785	87.53	88.27
561.54	283.0	21972	103.7	0.783	87.53	88.27
616.54	282.0	21972	103.4	0.781	87.53	88.27
674.94	281.0	21972	103.1	0.779	87.53	88.27
736.74	280.0	21972	102.8	0.777	87.53	88.27
801.94	279.0	21972	102.5	0.775	87.53	88.27
870.54	278.0	21972	102.2	0.773	87.53	88.27
942.54	277.0	21972	101.9	0.771	87.53	88.27
1017.94	276.0	21972	101.6	0.769	87.53	88.27
1096.74	275.0	21972	101.3	0.767	87.53	88.27
1178.94	274.0	21972	101.0	0.765	87.53	88.27
1264.54	273.0	21972	100.7	0.763	87.53	88.27
1353.54	272.0	21972	100.4	0.761	87.53	88.27
1445.94	271.0	21972	100.1	0.759	87.53	88.27
1541.74	270.0	21972	99.8	0.757	87.53	88.27
1640.94	269.0	21972	99.5	0.755	87.53	88.27
1743.54	268.0	21972	99.2	0.753	87.53	88.27
1849.54	267.0	21972	98.9	0.751	87.53	88.27
1958.94	266.0	21972	98.6	0.749	87.53	88.27
2071.74	265.0	21972	98.3	0.747	87.53	88.27
2187.94	264.0	21972	98.0	0.745	87.53	88.27



**利林電機工業股份有限公司**  
**FABMOTOR TECHNOLOGY CO., LTD.**  
 地址：台中市潭子區中山路三段 305 巷 54 號  
 ADD : NO. 54, LANE 305, SEC. 3, ZHONGSHAN RD.,  
 TANZI DIST., TAICHUNG CITY, TAIWAN 427  
 TEL : 886-4-25325909      FAX : 886-4-25326059  
 E-mail : admin@gearmotors.biz